

A close-up photograph of a mechanical assembly. In the center, there is a circular lens or sensor. Below it, a metal frame contains a grid of small, rectangular components, possibly sensors or actuators. The lighting is dramatic, with strong highlights and deep shadows, creating a technical and industrial atmosphere.

**DILATACIONE I SOKL
LAJSNE**

IROKO
N.B.O.V.S.



COFLEX CTL

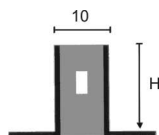

Dilatacioni profil

H = 8/10/12,5/15/20
 Dužina: 2,7m
 Materijal: CTL - AN aluminijum
 CTL - ON bakar
 CTL - IN inox
 Umetak: Guma
 Boja umetka: 51 - crna, 23 - cement siva



COFLEX CB

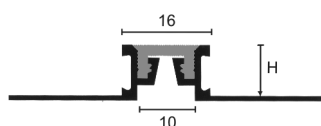

Dilatacioni profil

H = 8/10/12,5/15/20
 Dužina: 2,7m
 Materijal: CB - AN aluminijum
 CB - ON bakar
 Umetak: Sintetička smola
 Boja umetka: 51 - crna, 23 - cement siva

* za bakar



COFLEX CBL

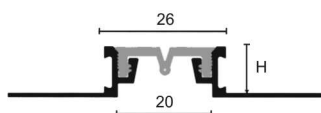

Dilatacioni profil

H = 8/10/12,5/15/20
 Dužina: 2,7m
 Materijal: CBL - AN aluminijum
 CBL - ON bakar
 Umetak: Sintetička smola
 Boja umetka: 51 - crna, 23 - cement siva

* za bakar



COFLEX CK

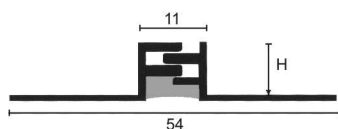

Dilatacioni profil

H = 10/12,5
 Dužina: 2,7m
 Materijal: CK - AN aluminijum
 CK - ON bakar



COFLEX CKM

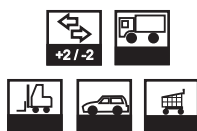
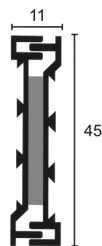

Dilatacioni profil

Dužina: 2,7m
 Materijal: CKM - AN aluminijum
 CKM - ON bakar



COFLEX CTM

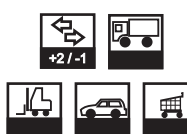
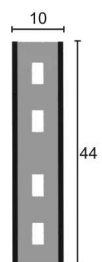

Dilatacioni profil

Dužina: 2,7m
 Materijal: CTM - ON bakar
 CTM - IN inox
 Umetak: Guma
 Boja umetka: 51 - crna, 23 - cement siva



JOINTEC GE/GEL

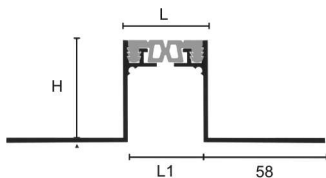

Dilatacioni profil

H = 20/50 L = 44/54 L1 = 38/48

Dužina: 4m

Materijal: GE/GEL - AN aluminijum

Umetak: Guma

Boja umetka: 51 - crna, 23 - cement siva

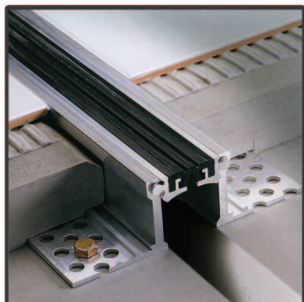

JOINTEC GR/GRL

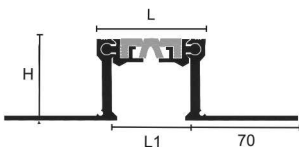

Dilatacioni profil

H = 20/50/70 L = 68/78 L1 = 46/56

Dužina: 4m

Materijal: GR/GRL - AN aluminijum

Umetak: Guma

Boja umetka: 51 - crna, 23 - cement siva

* GRL

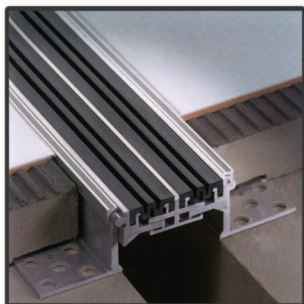

JOINTEC GRM

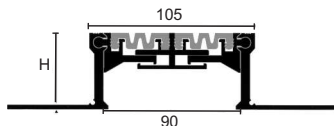

Dilatacioni profil

H = 50/70 L = 105 L1 = 90

Dužina: 4m

Materijal: GRM - AN aluminijum

Umetak: Guma

Boja umetka: 51 - crna, 23 - cement siva

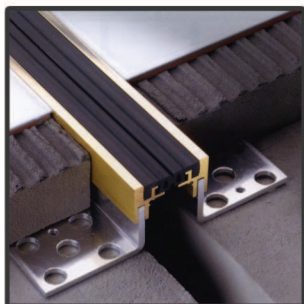

JOINTEC GM/GML

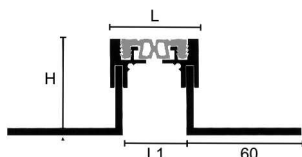

Dilatacioni profil

H = 35/50/75 L = 50/60 L1 = 38/48

Dužina: 3m

Materijal: GM/GML - AN aluminijum

GM/GML - ON bakar

GM/GML - IN inox

Umetak: Guma

Boja umetka: 51 - crna, 23 - cement siva

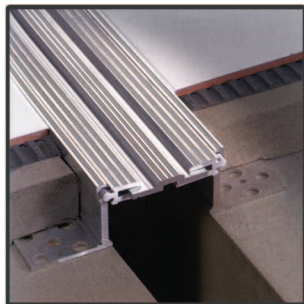

JOINTEC GAL



Dilatacioni profil

H = 20/50/70 L = 105 L1 = 86

Dužina: 4m

Materijal: GAL - AN aluminijum



JOINTEC GA

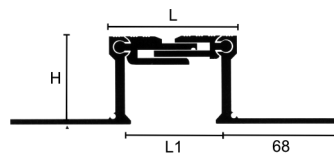

Dilatacioni profil

H = 20/50/70 L = 74 L1 = 54

Dužina: 4m

Materijal: GA - AN aluminijum

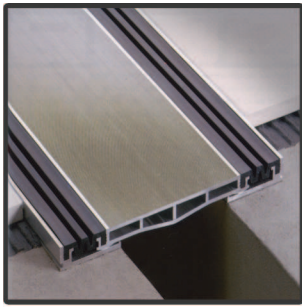

JOINTEC GS

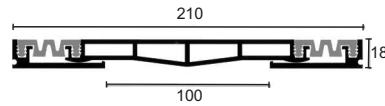

Dilatacioni profil za horizontalnu i vertikalnu dilataciju.

H = 18 L = 210 L1 = 100

Dužina: 4m

Materijal: GS - AN aluminijum

Umetak: Guma

Boja umetka: 51 - crna, 23 - cement siva

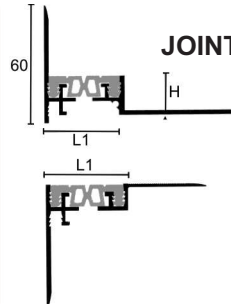
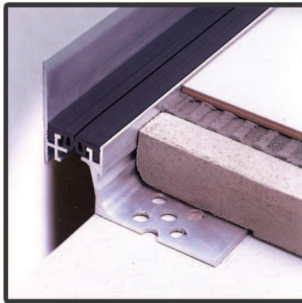

JOINTEC GEP/GELP GMP/GMLP GDP/GDLP

Dilatacioni profili

H = 20/50 35/75 12 L1 = 40/50 43/53

Dužina: 4m

Materijal: Aluminijum

Umetak: Guma

Boja umetka: 51 - crna, 23 - cement siva

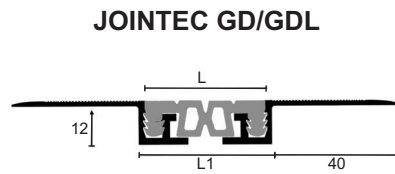
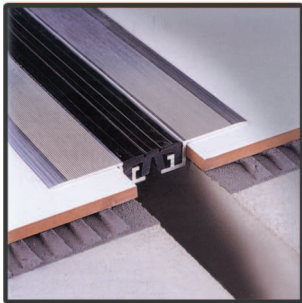

JOINTEC GD/GDL

Dilatacioni profil

H = 12 L = 37/47 L1 = 40/50

Dužina: 4m

Materijal: GD/GDL - AN aluminijum

Umetak: Guma

Boja umetka: 51 - crna, 23 - cement siva

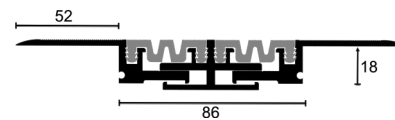
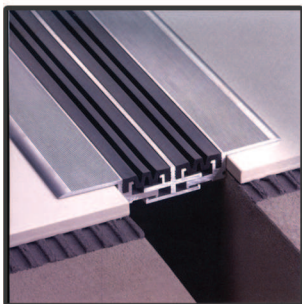

JOINTEC GDM

Dilatacioni profil

H = 18 L1 = 86

Dužina: 4m

Materijal: GDM - AN aluminijum

Umetak: Guma

Boja umetka: 51 - crna, 23 - cement siva

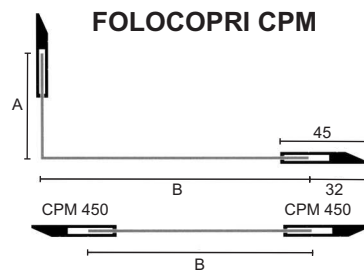
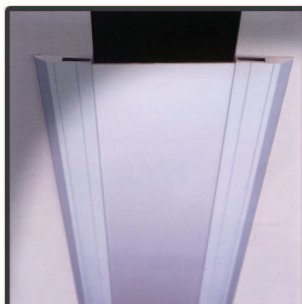

Dilatacioni profil za zidove i plafone

B = 45

Dužina: 2,7m

Materijal: CPM - AS eloksirani aluminijum

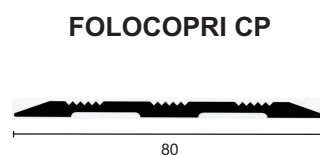

FOLOCOPRI CP

Dilatacioni profil

B = 80

Dužina: 2,7m

Materijal: CP - AS eloksirani aluminijum

CP - IL polirani nerđajući čelik

CP - OL polirani bakar

U ponudi su i samolepljivi profili.

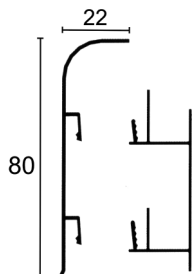

BI 80 ASN

Sokl lajsna
 Visina: H = 80
 Dužina: 3m
 Materijal: Eloksirani aluminijum

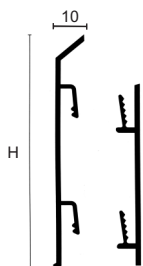

SKIRTING BI

Sokl lajsna
 Visina: H = 100
 Dužina: 3m
 Materijal: BI - ASN eloksirani aluminijum

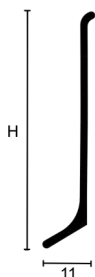
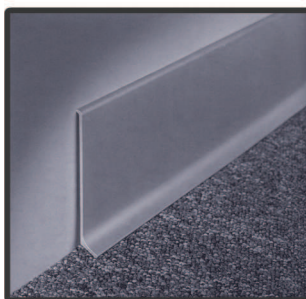

SKIRTING BA

Sokl lajsna
 Visina: H = 60/80/100
 Dužina: 2,7 m
 Materijal: BA - AS eloksirani aluminijum

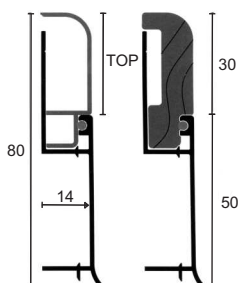
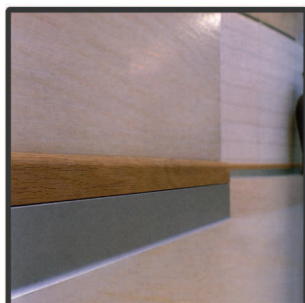

SKIRTING BI

Sokl lajsna sa podkonstrukcijom
 Dužina: 2 i 4 m
 Materijal: Eloksirani aluminijum
 Antracit - sivi aluminijum
 Drvo - hrast

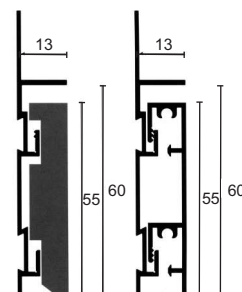
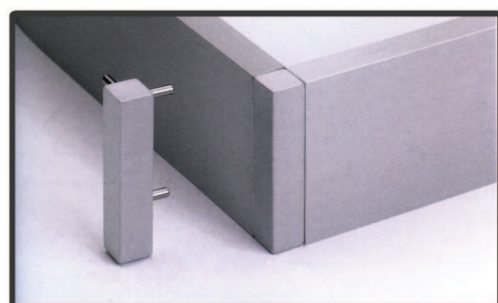
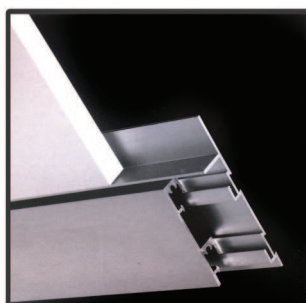

PLANO BF

Sokl lajsna sa podkonstrukcijom
 Visina: H = 60
 Dužina: 3m
 Materijal: Eloksirani aluminijum
 Drvo
 Aluminijum - belo

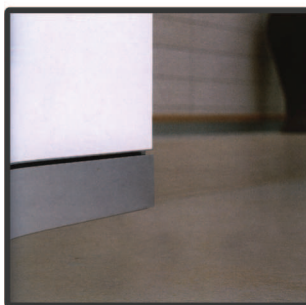



PRODAVNICA 1
Podzemni prolaz na Terazijama
(Hotel Moskva - Hotel Balkan)
Terazije br. 14
Beograd
Tel: 011/361-64-93



PRODAVNICA 2
Radnička br. 39
Beograd
Tel: 011/354-25-95



VELEPRODAJA
Makedonska br. 31/IV
Beograd
Tel: 011/33-73-562,
011/33-73-563
Fax: 011/33-73-567

Stalni smo izlagači
na sajmu gradjevinarstva u
Beogradu

MAGACIN
Gočka br. 51A
Beograd
Tel: 011/234-65-01

www.iroko.co.rs
irokobgd@sezampro.rs

IROKO